

Series HF-LF

HOUSINGS
HY-FLOW AND LARGE FLOW
STANDARD DESIGNER



CHARACTERISTICS:

- Construction 100% 316L SS fully electropolished
- V-Clamp or Rathmann type swing bolts closure
- Conform to 97/23/CE PED Directive
- Conform to 94/9/CE ATEX Directive
- V-Clamp design suitable for liquids Gr. 1 and 2 filtration
- Rathmann type swing bolts design suitable for both liquids and gas Gr. 1 and 2 filtration
- Side entry bottom outlet (other nozzles arrangement available as option)
- Suitable for pressure up to 8 bar (V-Clamp) or 10 bar (Rathmann bolts)
- Designed for MHF and MHL series depth cartridges
- Suitable to hold 1 to 3 cartridge stacks up to 40" long (standard); arrangement with larger cartridges quantity available (standard)
- Ideal for high flow-rate and low spare parts cost
- Cartridges reusable stainless steel core available in two design: welded to the tube sheet (standard) or dismountable (optional)
- O-ring head/body seal
- 304 SS adjustable legs (only for single cartridge design)
- Hydraulic test on 100% of manufactured units
- Customization for OEM customers

MAIN APPLICATIONS:

- DESALINATION
- WATER TREATMENT
- FINE CHEMICAL
- FOOD & BEVERAGE
- POWER GENERATION
- PAINTS AND RESINS
- PHARMACEUTICAL
- MICROELECTRONIC
- GALVANIC
- HYDRAULIC
- STEEL MILL
- GENERAL INDUSTRY

ASCO FILTRI

Series HF-LF

HOUSINGS
HY-FLOW AND LARGE FLOW
STANDARD DESIGNER

TECHNICAL DATA:

MAX. WORKING CONDITIONS

- 8 bar @ 80 °C (V-Clamp)
- 10 bar @ 100 °C (Rathmann)

CONSTRUCTION MATERIAL

Body:

- 316L SS / 304 SS (option)

V-Clamp (R):

- 316 SS micro cast

Micro Cast Head (F):

- 316 SS micro cast

Machined Head (M):

- 316L SS

ADJUSTABLE LEGS:

- 304 SS

FINISHING

Internal/external:

- Electropolishing
- Pickling (option)

GASKETS

- EPDM
- Silicone
- Viton
- FEP
- PTFE

IN/OUT

- 2" GAS-M
- 2.1/2" GAS-M
- 3" GAS-M
- DN 100 PN 16
- DN 150 PN 16

VENT

- 3/8" GAS-F

TUBE SHEET DRAIN

- 1/2" GAS-F

ACCESSORIES

- Pressure gauge
- Vent valve
- Flanged connections

Dimensions:

Model	Cartridge Type x q.ty	Q max. m³/h	Dimensions [mm]					In/out	Vol. [lt]	Weight [kg]	Fig.
			A	B	C	D	E				
HFR014	MHF 1x 40"	30	168.3	144	[1]	170.5	1027	2" / 3" Gas-m	24	32	1
LRF014	MHL 1x 40"	50	204	168	[1]	207.5	975	2" / 3" Gas-m	35	39	1
HFR034	MHF 3x 40"	90	273	240	[1]	310	1035	DN 100/150 PN16	80	70	1
HFM014	MHF 1x 40"	30	168.3	154	[1]	185	1090	2" / 3" Gas-m	26	42	2
LFF014	MHL 1x40"	50	204	170	[1]	236	987.5	2" / 3" Gas-m	36	50	2
HFF034	MHF 3x 40"	90	273	240	[1]	310	1012	DN 100/150 PN16	85	80	3
LFM034	MHL 3x40"	150	355.6	280		300	410	DN 150 PN 16	140	130	3

Max. flow-rate referred to 50 µm cartridges.
Clean delta-P 0.15 bar.
Shown flow-rates change depending on
installed filtration rating.

1] "C" dimension adjustable, according to
the selected model

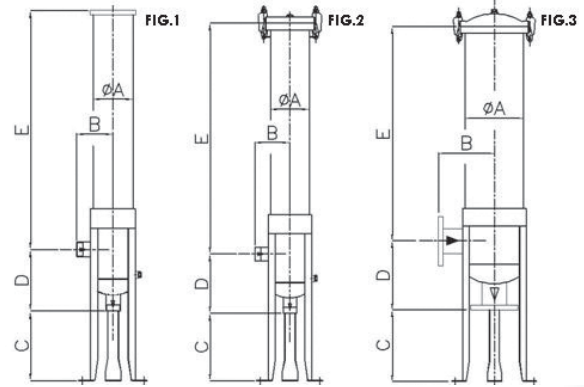

Max. working pressure:

Fluid	Model						
	HFR014	LRF014	HFR034	HFM014	LFF014	HFF034	LFM034
Liquido Gr. 2	8 bar	8 bar	8 bar	10 bar	10 bar	10 bar	10 bar
Liquido Gr. 1	8 bar	5.5 bar	2.5 bar	10 bar	10 bar	10 bar	10 bar
Gas Gr. 2	Not suitable			7.5 bar	5.5 bar	2 bar	1.3 bar
Gas Gr. 1	Not suitable			1.8 bar	1.3 bar	0.5 bar	0.3 bar

Where the 97/23/CE PED Directive is applicable, in case of dangerous liquids Gr. 1, the max. working pressure must be reduced. For different pressures contact ASCO Filtri.

Gaskets temperature limitation:

EPDM	120 °C	Viton	230 °C	PTFE	250 °C
Buna-n	120 °C	Silicone	230 °C	FEP	250 °C

Working temperature is limited from installed gaskets.
For different working temperature check with the operating manual.

Ordering information:

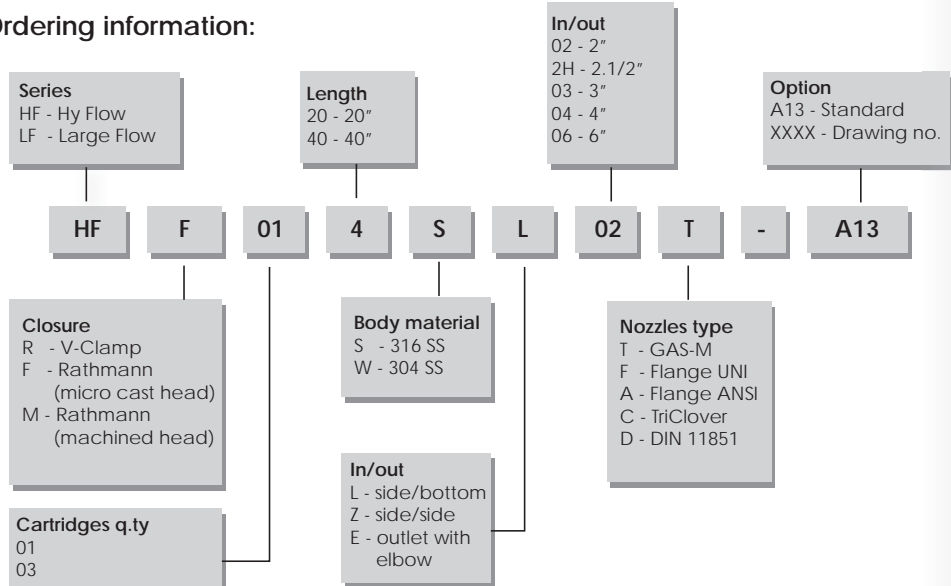

We reserve the right to change the data of this specification without notice.

ASCO Filtri s.r.l.

Via G. Brodolini, 1

20089 Rozzano (MI) - Italia

Phone: +39 02 89703.1

Fax: +39 02 89703.410

E-mail: asco@ascofiltri.com

Web: www.ascofiltri.com

ASCO
FILTRI